



Nordisk kernesikkerhedsforskning
Norrænar kjarnöryggisrannsóknir
Pohjoismainen ydinturvallisuustutkimus
Nordisk kjernesikkerhetsforskning
Nordisk kärnsäkerhetsforskning
Nordic nuclear safety research

NKS-176
ISBN 978-87-7893-242-6

Speciation Analysis of Radionuclides in the Environment. NKS-B Speciation project report 2007

Xiaolin Hou (1), Ala Aldahan (2), Göran Possnert (3),
Galina Lujaniene (4), Juka Lehto (5) and Brit Salbu (6)

- (1) Risø National Laboratory for Sustainable Energy, DTU, Denmark
(2+3) Uppsala University, Sweden
(4) Institute of Physics, Lithuania
(5) University of Helsinki, Finland
(6) Norwegian University of Life Sciences (UMB), Norway

July 2008

Abstract

This report describes the work carried out under the NUK-B project SPECIATION 2007. In 2007, the project partners had two meetings in April and November, organized a NUK seminar on speciation and hot particles. SPECIATION 2007 mainly focused on two issues on speciation (1) further development of speciation methods for radionuclides, and (2) investigation of speciation of radionuclides in environment. The report summarized the work done in partners labs, which includes: (1) Further development on the speciation of ¹²⁹I and ¹²⁷I in water samples; (2) Speciation method for ¹²⁹I and ¹²⁷I in air; (3) Dynamic system for fractionation of Pu and Am in soil and sediment; (4) Investigation on Re-absorption of Pu during the fractionation of Pu in soil and sediment; (5) Speciation of ¹²⁹I in North Sea surface water; (6) Partition of ¹³⁷Cs and ¹²⁹I in the Nordic lake sediment, pore-water and lake water; (7) Sequential extraction of Pu in soil, sediment and concrete samples, (8) Pu sorption to Mn and Fe oxides in the geological materials, (10) Investigation of the adsorbed species of lanthanides and actinides on clays surfaces. In addition, two review articles on the speciation of plutonium and iodine in environmental have been planned to be submitted to an international journal for publication.

Key words

Speciation, radionuclides, radioecology, radioanalytical chemistry, ¹²⁹I, plutonium, fractionation, dynamic system

NKS-176
ISBN 978-87-7893-242-6

Electronic report, July 2008

The report can be obtained from
NKS Secretariat
NKS-776
P.O. Box 49
DK - 4000 Roskilde, Denmark

Phone +45 4677 4045
Fax +45 4677 4046
www.nks.org
e-mail nks@nks.org

Speciation Analysis of Radionuclides in the Environment

Edited by Xiaolin Hou
Radiation Research Department, Risø DTU, DK-4000, Roskilde, Denmark

Abstract

This report describes the work carried out under the NUK-B project SPECIATION 2007. In 2007, the project partners had two meetings in April and November, organized a NUK seminar on speciation and hot particles. SPECIATION 2007 mainly focused on two issues on speciation (1) further development of speciation methods for radionuclides, and (2) investigation of speciation of radionuclides in environment. The report summarized the work done in partners labs, which includes: (1) Further development on the speciation of ^{129}I and ^{127}I in water samples; (2) Speciation method for ^{129}I and ^{127}I in air; (3) Dynamic system for fractionation of Pu and Am in soil and sediment; (4) Investigation on Re-absorption of Pu during the fractionation of Pu in soil and sediment; (5) Speciation of ^{129}I in North Sea surface water; (6) Partition of ^{137}Cs and ^{129}I in the Nordic lake sediment, pore-water and lake water; (7) Sequential extraction of Pu in soil, sediment and concrete samples, (8) Pu sorption to Mn and Fe oxides in the geological materials, (10) Investigation of the adsorbed species of lanthanides and actinides on clays surfaces. In addition, two review articles on the speciation of plutonium and iodine in environmental have been planned to be submitted to an international journal for publication.

Keywords: Speciation, radionuclides, radioecology, radiochemistry, ^{129}I , plutonium

NKS-B SPECIATION project participants:

Risø National Laboratory, Radiation Research Department, Technical university of Denmark, DK-4000 Roskilde, Denmark (Xiaolin Hou (coordinator), Roongrat Petersen)

University of Helsinki, Department of Chemistry, Laboratory of Radiochemistry, P.O. Box 55, FIN-00014 Helsinki, Finland (Juka Lehto)

Institute of Physics, Nuclear and Environmental Radioactivity Research Laboratory, Savanoriu 231, LT-0230 Vilnius, Lithuania (Galina Lujaniene)

Norwegian University of Life Sciences (UMB), Dep. of Plant- and Environmental Sciences, P.O.Box 5003, N-1432 Ås, Norway (Brit Salbu, Ole Christian Lind, Linds Skipperud)

Uppsala University, Department of Earth Science, Villavägen 16, SE-752 36 Uppsala, Sweden (Ala Aldahan)

Uppsala University, Tandem Laboratory, Uppsala University, SE-751 21 Uppsala, Sweden (Göran Possnert)

Acknowledgment

NKS conveys its gratitude to all organizations and persons who by means of financial support or contributions in kind have made the work presented in this report possible.

Content

1. *Background and Introduction*
2. *Overview of the activity on speciation of radionuclides in Nordic laboratories*
3. *NKS Speciation/Hot particles Seminar*
4. *Progress in the method development for speciation of radionuclides*
 - 4.1. *Further development on the speciation of ^{129}I and ^{127}I in water samples*
 - 4.2. *Speciation method for ^{129}I and ^{127}I in air*
 - 4.3. *Dynamic system for fractionation of Pu and Am in soil and sediment*
 - 4.4. *Investigation on Re-absorption of Pu during the fractionation of Pu in soil and sediment*
5. *Progress in the investigation of speciation of the some radionuclides in specific Nordic environments*
 - 5.1. *Speciation of ^{129}I in North Sea surface water*
 - 5.2. *Partition of ^{137}Cs and ^{129}I in the Nordic lake sediment, pore-water and lake water*
 - 5.3. *Sequential extraction of Pu in soil, sediment and concrete samples*
 - 5.4. *Pu sorption to Mn and Fe oxides in the geological materials*
 - 5.5. *Investigation of the adsorbed species of lanthanides and actinides on clays surfaces (University of Helsinki)*
6. *Structure of review articles*
 - 6.1 *Speciation of Plutonium in Environmental Samples*
 - 6.2 *Speciation of Iodine (^{129}I) in the Environment*

1. Background and Introduction

In order to assess short- and long term consequences of radioactive contamination in the environment, information on the source term including the distribution of physico-chemical forms (speciation), transformation processes occurring after release and deposition as well as the kinetics involved is needed. Such information can be obtained by means of radionuclide speciation analysis, which is defined as the application of analytical techniques to identify and quantify radionuclide species in a sample. Generally it can be stated that the speciation of an element has a direct influence on the toxicity, mobility, bioavailability, bioactivity, transport, uptake etc. Thus, elemental speciation is a multidisciplinary research field important to environmental sciences as well as geology and bioinorganic chemistry, clinical and medical chemistry and more. Determination of the total concentration of the element alone is not sufficient and may lead to erroneous conclusions. Speciation analysis is necessary for the evaluation of the risks of pollutants in the environment, the bioavailability of elements in soils or plants and the transport mechanisms of metals to the human body.

In general, the risk perspective has driven the major part of research conducted on the behaviour of natural radioisotopes as well as anthropogenic radioisotopes in the environment. This has been a natural consequence of the nuclear weapons programme and the development of nuclear power for civil use. It should however be kept in mind that for decades radioisotopes have been used for environmental tracer purposes. Radioisotopes have been used in large-scale systems such as determination of gas-exchange rates between the atmosphere and the oceans or quantification of world ocean circulation but also in microscopic events such as colloid aggregation and exchange interaction between molecules. Regardless of purpose, knowledge on the behaviour of the different radioisotopes is a key issue whether it serves to determine the possible pathways to human exposure or if it serves as a potential tracer for some process. If and when the released or *in-situ* generated radioisotopes will take part in the global cycles of matter, depends to a large degree on the exchange with the environment and thus its speciation. This speciation may very well be site-specific in the sense that the chemical species of ^{129}I (or ^{131}I) released from a reprocessing plant (nuclear power plant) may be very different from those of naturally occurring iodine due to the specific chemicals used for processing or due to radiolysis (caused by the high activity concentrations). It may thus not necessarily be possible to use the knowledge of stable iodine as a proxy for radioactive iodine (Wershofen & Aumann, 1989; Noguchi & Murata, 1988). A similar situation goes for cobalt where the radioactive Co(III) species may be expected to be more frequent (Cooper & Mchugh, 1983). Without knowledge on the speciation of the radioisotopes there will be increased uncertainties as to what risk they pose and their use as tracers will be less clear.

Refractory radionuclides from nuclear weapons testing and reactor accidents are mostly present as radioactive particles, whereas the volatile radionuclides released, such as ^{131}I , ^{129}I , ^3H , and ^{14}C may exist as gaseous compounds as well as associated with aerosols (Von Gunten & Benes, 1994). The radionuclides in effluents from nuclear installations and contamination from nuclear repositories are present as colloids and low molecular mass species such as ions, molecules, complexes (Salbu et al. 2004). Low molecular mass species are more mobile and can have a high bioavailability whereas particles and colloids are biologically inert although they can be retained through filtering (e.g. in the lungs or by filtering organisms). All the radioactive species exist in a dynamic interaction where ions and molecules can grow through hydrolysis, complexation and aggregation and low molecular species may be released from particles through desorption mechanisms, dissolution etc. In general the water phase is a major mode through which radionuclide species undergo chemical reactions and transport, and are made available to biota for uptake. Soils and sediments, the second and longer term sink for radionuclides, are dynamic systems where the long-term phase partitioning of the radionuclides is affected by processes such as burial, diagenesis, percolation, biological activity, adsorption/absorption and desorption, mineralogical transformations, and changes of pH (acidity/alkalinity) and Eh (reduction/oxidation potential).

Risk assessment has to be carried out before setting up repositories for radioactive waste from nuclear facilities. Increasingly sophisticated risk assessment models can be improved by including information on the radionuclide speciation in soils, sediments, water, plants and animals. Furthermore, selection of site-specific remediation strategies can be more cost effective by incorporating decisions on critical processes based on reliable radionuclide speciation information. In the Nordic countries, more nuclear reactors are being decommissioned and radioactive waste will be generated in that process. To evaluate the short- and long-term environmental impact of repositories, speciation data of the relevant radionuclides must be acquired. Many radionuclides are of importance to the risk assessment in connection to repositories i.e. ^{14}C , ^{36}Cl , ^{99}Tc , ^{129}I , and the actinides. However, site-specific conditions and chemical compounds used in the repositories, or in the power plants, may severely alter the speciation of some elements, which therefore may necessitate development of local knowledge. The isotopes of U have been studied in quite some detail previously with risk assessment in mind whereas the knowledge of the speciation of ^{99}Tc , ^{237}Np and the isotopes of Pu is far from complete (Moulin and Moulin 2001). Therefore, our primary aim is to study the speciation of the radioactive isotopes of I, Pu, Tc and Np and provide data on key processes that control the mobility and transport/transfer of these radionuclides in the environment.

Extensive experience with sequential extraction, co-precipitation, solvent extraction, ion exchange, extraction chromatography, size exclusion chromatography, high performance liquid chromatography and synchrotron radiation based x-ray techniques for the speciation of radionuclides in

environmental samples have been accumulated in the Nordic countries. For the analysis of radionuclides various radiometric techniques, such as gamma, beta and alpha spectrometry have been very well used in all Nordic radiochemical laboratories. ICP-MS and AMS have developed to a state of the art technique for the detection of long-lived radionuclides with detection limits better than conventional radioactivity detectors. In order to obtain information on the source(s) of the released radionuclides, speciation analysis may be combined with advanced techniques such as Inductively Coupled Plasma Mass Spectrometry (ICP-MS) and Accelerator Mass Spectrometry (AMS) for the determination of isotope ratios and activity concentrations of long-lived radionuclides (e.g. actinides) at ultra low level in obtained fractions (Lind et al in press). ICP-MS offers simultaneous determination of many elements with high sensitivity and very low detection limits (sub-ppt for most elements), easy access to isotopic information of the elements and most importantly very versatile coupling to many chromatographic techniques such as high performance liquid chromatography, capillary electrophoresis, size exclusion chromatography, ion chromatography, gel electrophoresis and gas chromatography (Cornelius et al. 2003). The coupling of ICP-MS to a chromatographic technique is what is needed to do elemental speciation analysis. Based on the retention times on the chromatographic column the molecules can be identified and the ICP-MS analyser is used for the identification of the elemental content as well as for accurate and ultra-sensitive analysis.

Although much work has been carried out, the knowledge on the speciation of several radionuclides is still limited (Skipperud et al. 2000b; Ochs et al. 2003; Salbu et al. 2004, Moulin and Moulin 2001). This situation results from the difficulties in the identification and assessment of various species of radionuclides in the environment and their low environmental concentrations (Von Gunten and Benes 1994) thus requiring *state-of-the-art* analytical instrumentation coupled to high performance separation techniques. Fortunately the recent instrumental development has made possible speciation studies of trace elements at environmental levels. This is mainly due to improvements connected to synchrotron radiation based x-ray techniques and the inductively-coupled mass spectrometry (ICP-MS) technique, but also due to improvement in the speciation tools such as capillary electrophoresis with volume handling suitable for direct ICP-MS injection.

Some Nordic laboratories have worked on radionuclide speciation for many years and gained considerable experience and knowledge (Salbu, 2000, 2004; Hou, 2001; 2003; Keith-Roach et al, 2003; 2004; Puhakainen, et al. 2001; Skipperud, et al. 2006; Outola et al. 2003; Vaaramaa et al. 2003). But no close collaboration among these Nordic laboratories was carried out in the field before this project, although two workshops on the radionuclide speciation have been organized by a Nordic laboratory (Norwegian University of Life Science, Workshop, 2002, 2005). This project (NKS – SPECIATION) was launched in 2007, through this project a close collaboration among Nordic laboratories on speciation of radionuclides has been established, and the experiences on the

speciation analysis of radionuclides obtained in the individual laboratory were exchanged and shared.

The aims of this project in 2007 are: (1) Overview of the research activity on speciation of radionuclides in Nordic countries, and establish a close collaboration among Nordic laboratories for speciation of radionuclides; (2) Organization of a NSK seminar on speciation of radionuclides; (3) Further development and improvement of analytical methods for speciation of some important radionuclides in the environment, such as Pu, Am, Np, and ^{129}I , (4) Investigation of speciation of the some radionuclides in specific Nordic environments, such as the plutonium contamination in Thule, Greenland, issues related to Nordic repositories for nuclear waste and the behaviour in Nordic waters of radionuclides from European reprocessing facilities.

References:

- Cooper E.L., McHugh J.O. (1983) *Sci. Total Environ.* 28:215-230.
- Cornelius, R., Caruso, J., Crews, H. Heumann, K. (editors) (2003), *Handbook of Elemental Speciation: Techniques and Methodology*, Wiley, Chichester.
- Hou X.L., Dahlgaard H. & Nielsen, S.P. (2001). *Mar. Chem.* 74: 145-155.
- Hou X.L., Fogh C.L., Kucera J. (2003). *Sci. Total Environ.* 308:97-109
- Keith-Roach M.J., Morris K., Dahlgaard H. (2003). *Mar. Chem.*, 81:149-162.
- Keith-Roach, M.J.; Roos, P. (2004). *Estuar. Coast. Shelf Sci.* (2004) 60: 151-161
- Lind O.C., Oughton D.H., Salbu B., Skipperud L., Sickel M.A., Brown J.E., Fifield L.K. and Tims S., (2006). Transport of low $^{240}\text{Pu}/^{239}\text{Pu}$ atom ratio plutonium-species in the Ob and Yenisey Rivers to the Kara Sea, *Earth and Planetary Science Letters*, in press.
- Moulin V., Moulin, C., (2001). *Radiochim. Acta*, 89:773-778.
- Noguchi H., Murata M. (1988), *J. Environ. Radioactivity*, 7:65-74.
- Ochs, M., Lothenbach, B., Shibata, M., et al. (2003). *J. Contam. Hydrol.*, 61:313-328.
- Outola I., Pehrman R., Jaakkola T.(2003), *Sci. Total Environ.*, 303(3)221-230.
- Puhakainen, M., Riekkinen, I., Heikkinen, T., Jaakkola, T., Steinnes, E., Rissanen, K., Suomela, M., Thørring, H. (2001) *J. Environ. Radiat.* 52(1), 17-29.
- Salbu, B. (2000), *Speciation of radionuclides in the environment*, R.A. Meyers Ed. *Encycl. Anal. Chem.*, John Wiley & Son Ltd., Chichester.
- Salbu, B., Lind, O.C., Skipperud, L., (2004). *J. Environ. Radioact.*, 74:233-242.
- Skipperud, L. Oughton, D. H., Fifield, L. K., Lind, O. C., and Brown, J., (2006) "Plutonium speciation in Ob and Yenisey Estuaries and Rivers" Submitted to *Journal of Environmental Radioactivity*.
- Skipperud L., Oughton D., Salbu B.(2000b). *Health Phys.* 79(2):147-153
- Vaaramaa, K., Lehto, J., Ervanne, H. (2003), *Radiochim. Acta.* 91(2003)21.
- Von Gunten H.R., Benes P. (1994). *Speciation of radionuclides in the environment (technical report)*, Paul Scherrer Institute, Switzerland, PSI-BER-94-03.
- Wershofen H., Aumann D.C. (1989), *J. Environ. Radioactivity*, 10:141-156.

Workshop, 2002, Advanced techniques and radionuclide speciation within radioecology, August 30-31, 2002, Monaco

Workshop, 2005, Advanced techniques and radionuclide speciation within radioecology, Sept. 30-Oct. 1st, 2005, Monaco.

2. Overview of the activity on speciation of radionuclides in Nordic laboratories

Many laboratories in the Nordic countries have been carrying out the speciation of radionuclides in for many years. A summary of the activity in the participants' laboratories in this project is listed below.

2.1 Risø, Denmark

- Liquid samples (< 0.45 water, ^{129}I (oxidation), Pu, Am, Tc, Cs, Sr, etc.)
- Solid sample (soil, sediment), sequential extraction of ^{129}I , Pu, Am, Cs, Sr
- Plant (seaweed), ^{129}I , ^{99}Tc , English Channel, North Sea
- Air sample (^{129}I speciation, particles, inorganic and organic gaseous iodine), Source?

2.2 Uppsala university, Sweden

- Radionuclides measurement by AMS: (^{129}I , ^{10}Be , ^{14}C , other)
- Baltic Sea samples (^{129}I , water, sediment), 0.3-1.0 liter water. speciation and fractionation.
- Lake sediment (total, depth profile, fractionation), ^{137}Cs , ^{14}C , ^{210}Pb
- Tree ring, tracks, ^{129}I , ^{14}C
- Precipitation (rain, snow), ^{127}I , ^{129}I (total, speciation), transport of ^{129}I from reprocessing plant.
- $^{7,10}\text{Be}$ airsoles, climate, environment, (speciation), ^{129}I ice cores from Greenland, sediment, ^{137}Cs mark of 1986 Chernobyl, in different minerals.
- ^{14}C . tracer, dynamic studies

2.3 Institute of Physics, Lithuania

- Be, ^{137}Cs in air, solubility, fractionation.
- Pu, airsole, fractionation, Isotopic ratio, transfer,
- Pu, redox states, lab exp. extraction, MS method,
- minerals, Pu, oxidation, surface chem. minerals, fractionation,
- Soil, sediment, fractionation, Pu, Am, Cs, Sr, Re-adsorption, one-year exp.

- Hot particles, fractionation.

2.4 University of Helsinki, Finland

- Seq. extraction of soil and sediment for Am, Cs, Pu,
- Pu oxidation in lake water (co-precipitation), LnF_3 method
- U oxidation in ground water.
- Distribution of Po, U, Pb Ra, in ground water, by filtration,
- Particle characterization of uranium and transuranics
- Actinides, surface of Al, Si (LIFS), solution and solid phases, theoretical and experimental ways. (Kaolinite, Gibbsite) Model exp.

2.5 Norwegian University of Life Sciences (UMB), Norway

- Water fractionation for radionuclides (0.45mm, HF, chromatography. 1-10-100 kda, +, -, neut., Sellafield, L Hague, Chernobyl, Kara, Mayak, U mining, ETNORM,) Rorholt lake (anoxic/oxic), etc.
- Water (ground, lake, river) in Mayak, (particle(fallout), colloid and LMM(weapons))
- Soil, sediment (hot pat.) sequential extr., (procedure), incub (NH_4Ac), 0.1 HCl extraction, SEM/XRMA, XANEF, XRD, XRF (3-dimension), ICP-MS (ratios)
- Sub.Nano Part. (EELS, $\text{Fe}^{3+}/\text{Fe}^{2+}$) (Fe, Al, Mn, TOC), Iso ratio of stable Fe in river
- TENORM (U, Th and their decay series), Speciation or fractionation in water, fish

2.6 Common work of speciation in Nordic Labs

- Size fractionation, sequential Fractionation, oxidation states
 - Radionuclid: $^{239,240}\text{Pu}$, ^{129}I , ^{238}U , ^{232}Th , ^{137}Cs , (^{241}Am)
 - Sample: Sediment and soil for Pu, I, U, Th,
 - Method: Individual protocol and the common protocol. (HU, PI, UMB, Risø)
- (Fractions: exchangeable, carbonate, oxides, organic matter, residues)

3. NKS Speciation/Hot particles Seminar

A NKS seminar has been organized through this project and cooperation with NKS HOT project in April 2007, about 40 scientists participated the seminar and 22 presentations were given, the problems, techniques, and future need were discussed, a proceeding of this seminar is preparing. The program of the seminar is given below.

NKS seminar on radionuclide speciation and radioactive particle studies in a Nordic context

Norwegian University of Life Sciences (UMB)
April 19th and 20th, 2007

PROGRAMME

DAY 1: Radionuclide speciation studies in a Nordic context

10:00	Coffee and welcome	Rektor Knut Hove, UMB
10:10-12:30	Session 1: Radionuclide speciation in aquatic systems	Chair: Ala Aldahan, Uppsala University, Sweden Brit Salbu, UMB, Norway
10:10 -10:50	Eiliv Steinnes, NTNU/UMB, Norway	Trace element speciation in aquatic systems: general principles and selected examples
10:50 -11:30	Hans Christian Teien, UMB, Norway	Metal-speciation in unstable aquatic mixing zones and relevance for fish
11:30-11:50	Xiaolin Hou Risø National Laboratory, Denmark	Chemical speciation of ¹²⁹ I in North Sea water and its application for the study of marine geochemical cycle of stable iodine
11:50-12:10	Ole Christian Lind, UMB, Norway	Size fractionation and accelerator mass spectrometry analysis of Pu in the Ob and Yenisey rivers
12:10-12:30	Discussion	
12:30-13:30	Lunch	
13:30-16:30	Session 2: Solid phase radionuclide speciation	Chair: Göran Possnert, Uppsala University, Sweden Hans Christian Teien, UMB, Norway
13:30-14:10	Zhifang Chai, Chinese Academy of Science, Beijing, China	Study of chemical species of some essential and toxic elements by nuclear and related methods
14:10-14:50	Jussi Jernström, Risø National Laboratory, Denmark	Metal concentrations in the sediments of Lake Umbozero in Kola, Russia
14:50-15:10	Coffee and fruits	
15:10-15:30	Roongrat Petersen, Risø National Laboratory, Denmark	Dynamic Chemical Fractionation of Metals and Radionuclides in Soils and Sediments
15:30-15:50	Lindis Skipperud, UMB, Norway	Association of Plutonium with soil and sediments contaminated from Mayak and Krasnoyarsk nuclear installations
15:50-16:10	Galina Lujaniene, Institute of Physics, Lithuania	Cs, Pu and Am speciation and sorption behaviour under cement-based repository conditions
16:10-16:30	Brit Salbu, UMB, Norway	Fractionation techniques useful for speciation studies
16:30-17:00	General discussion – future needs	Chair: Jukka Lehto, Helsinki University, Finland Eiliv Steinnes, NTNU/UMB, Norway
17:00	Departure for dinner in Drøbak	
18:00-	Dinner	Oscarsborg fortress, Drøbak

DAY 2: Radioactive particle studies in a Nordic context

09:00	Welcome	Tove Fjeld, Head of Department of Plant and Environmental Sciences
09:10-12:10	Session 1: Sources and characteristics of radioactive particles	Chair: Xiaolin Hou, Risø National Laboratory, Denmark Lindis Skipperud, UMB, Norway
09:10-09:50	Brit Salbu, UMB, Norway	Sources of radioactive particles of relevance for the Nordic environment
09:50-10:10	Per Roos, Risø National Laboratory, Denmark	Terrestrial contamination from the Thule-68 accident
10:10-10:30	Ole Christian Lind, UMB, Norway	Application of ESEM and synchrotron radiation based microbeam techniques in radioactive particle characterisation
10:30-10:50	Coffee	
10:50 -11:10	Roy Pöllänen, STUK, Finland	Direct alpha spectrometry from air samples containing nuclear fuel particles
11:10 -11:30	Mats Eriksson, IAEA-MEL, Monaco	The use of advanced analytical techniques for hot particle characterisation - How useful are they and how should we apply the results in radioecology studies?
11:30-12:10	Maria Carmen, University of Seville, Spain	Characterisation of Palomares particles
12:10-13:00	Lunch	
13:00-14:00	Session 1 continue	Chair: Zhifang Chai, Chinese Academy of Science, China Mikhail Iosjpe, NRPA, Norway
13:00-13:20	Mats Eriksson, IAEA-MEL, Monaco	The use of SIMS and SEM for the characterization of individual particles originating from nuclear weapons material
13:20-13:40	Lindis Skipperud, UMB, Norway	Isotope-ratios for source identification, measured by AMS and ICP-MS
13:40-14:00	Rafael Garcia-Tenorio, University of Seville, Spain	Terrestrial hot-particles dispersed in the Palomares accident: actinide composition and bioavailability experiments
14:00-14:20	Coffee and fruits	
14:20-15:20	Session 2: Impact and application of radioactive particles	Chair: Mats Eriksson, IAEA-MEL, Monaco Justin Brown, NRPA, Norway
14:20-14:40	Jerzy Bartnicki, met.no, Norway	Atmospheric dispersion of radioactive particles from nuclear explosions - SNAP model results
14:40-15:00	Mikhail Iosjpe, NRPA, Norway	Problems in implementing non-constant Kds in radionuclide transport and dose assessment models
15:00-15:20	Deborah H. Oughton, UMB, Norway	Uncertainties in environmental impact assessment: Sources and Typology
15:20-16:00	General discussion	Chair: Per Roos, Risø National Laboratory, Denmark Ole Christian Lind, UMB, Norway
16:00	Meeting closed	

4. Progress in the method development for speciation of radionuclides

4.1. Further development on the speciation of ^{129}I and ^{127}I in water samples (Risø/Uppsala University)

The chemical separation method was further developed for the separation of ^{129}I and stable iodine in water samples, including seawater, lake water and precipitation. Iodide, iodate and organic iodine were separated, the separated iodine was concentrated by Solvent extraction using CCl_4 and prepared as AgI for AMS measurement of ^{129}I . The separated iodine species were directly measured by ICP-MS after adding ammonium to 1%. The developed chemical separation procedure is shown below.

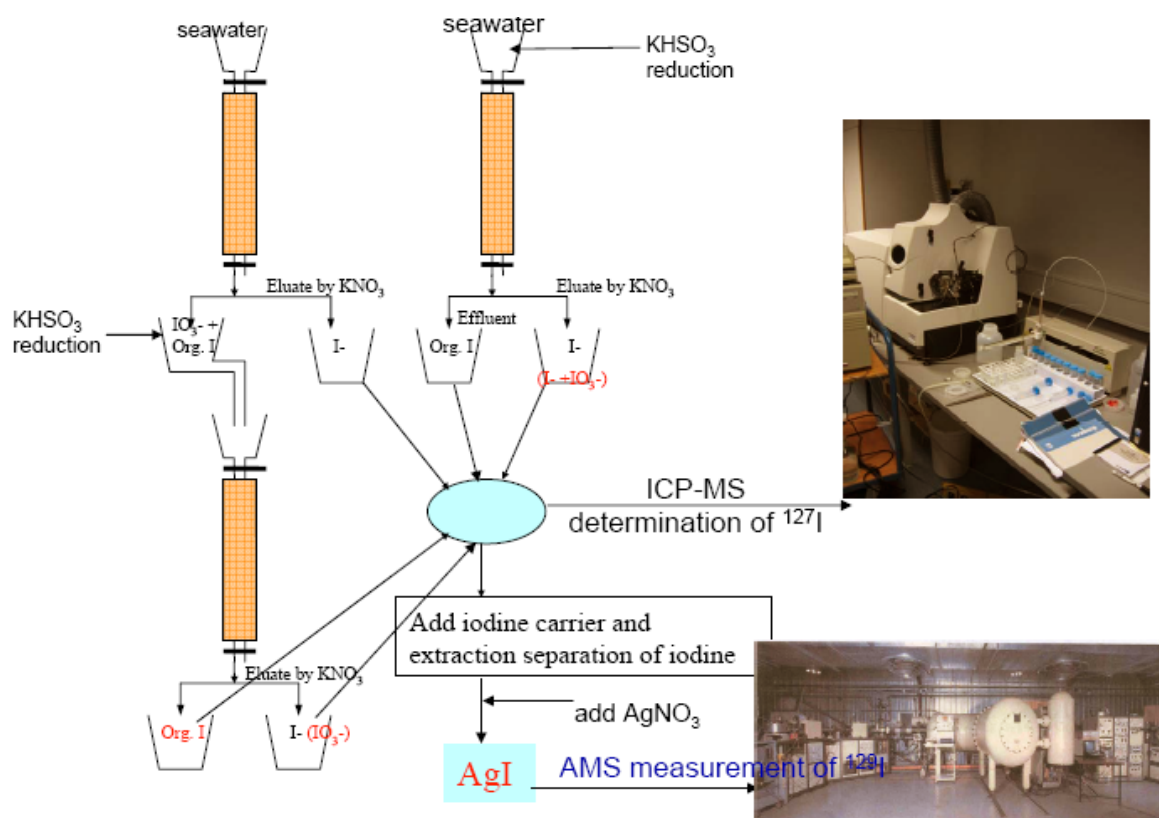

Fig.1 Chemical separation procedure for the chemical speciation analysis of iodine in water samples.

4.2. Speciation method for ^{129}I and ^{127}I in air (Risø/Uppsala university)

A method for the collection and separation of different species of iodine in air was further developed. In this method, particle associated iodine, inorganic gaseous iodine and organic gaseous io-

dine was collected by pumping the air through air sampler with sequential air filters as show in Fig. 2. In which the particle associated iodine was first collected on a glass fibre filter with pore size of $0.45\ \mu\text{m}$, the gas components passed through the filter. Inorganic gaseous iodine, such as I_2 , HI , HIO are then trapped by cellulous filter which was impregnated in NaOH /glycerol and dried. Finally the organic gaseous iodine, mainly alkane iodide, such as CH_3I and $\text{CH}_3\text{CH}_2\text{I}$ was trapped in a column filled with active charcoal which was impregnated with TEDA. Fig. 3 shows the air sampler for the collecting air sample.

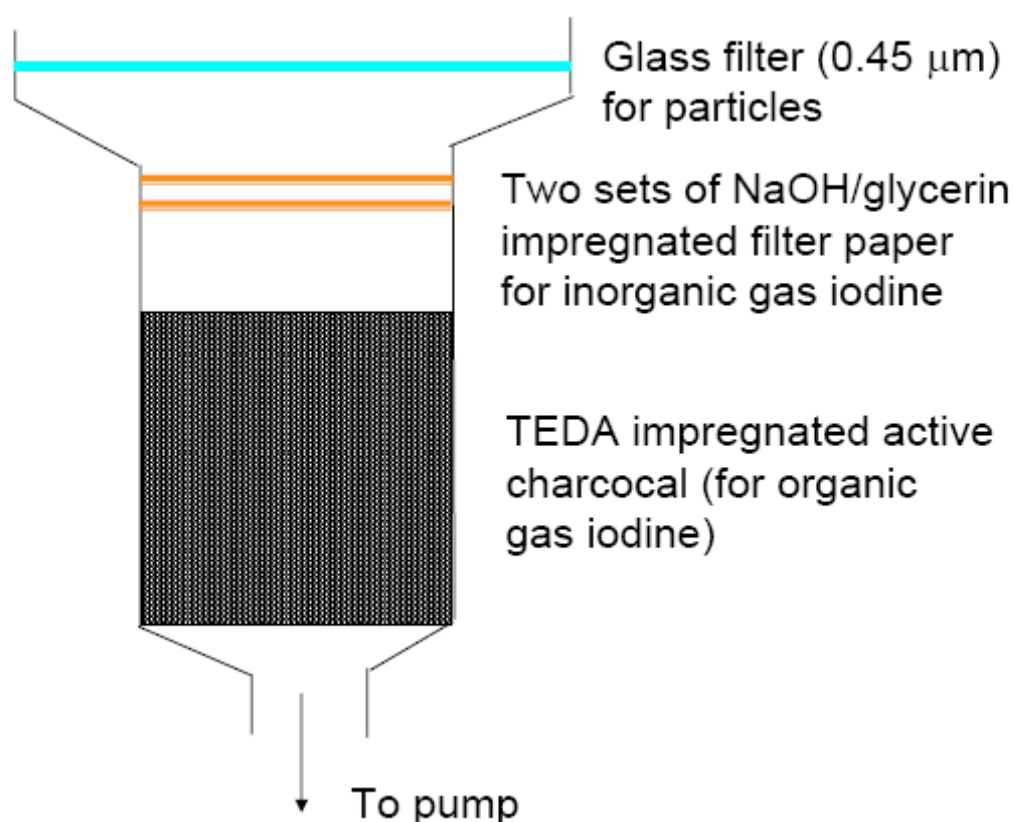

Fig.2 Air sampler for the collecting particle associated iodine, inorganic gas iodine and organic gas iodine.

The collected different species of iodine were then separated by a combustion method (Fig.4). In this method, the collected sample was put into a quartz boat, and ^{125}I as yield tracer was added to the sample. The sample boat was then put in a quart tube which was heated by a tube oven, compressed air and oxygen gas pass through the tube during heating. The iodine released during heating up to $800\ ^\circ\text{C}$ was then trapped by two set of bubbler filled with $0.2\ \text{mol/l}$ NaOH solution. One ml of tapped solution was taken for the determination of ^{127}I by ICP-MS. The remained solution was used

for the separation of iodine and AMS determination of ^{129}I by solvent extraction method and AgI precipitation method as the same as for water sample.



Fig.3 Air sampler for collected different species of iodine from atmosphere



Fig. 4 Combustion equipment for the separation of iodine from solid samples

4.3. Dynamic system for fractionation of Pu and Am in soil and sediment (Risø)

A dynamic extraction system (Fig.5) exploiting sequential injection (SI) for sequential extractions incorporating a specially designed extraction column (Fig.6) was developed to fractionate radionuclides such as Pu, Am, Np and ^{137}Cs in environmental solid samples such as soils and sediments.

The extraction column can contain a large amount of soil sample (up to 5 g), and under optimal operational conditions it does not give rise to creation of back pressure. The purpose of developing such a dynamic system for fractionation of radionuclides is to reduce the readsorption problems during sequential extraction using a modified Standards, Measurements and Testing (SM&T) scheme with 4-step sequential extractions. In addition, the dynamic system is more similar as the situation occurring in nature.

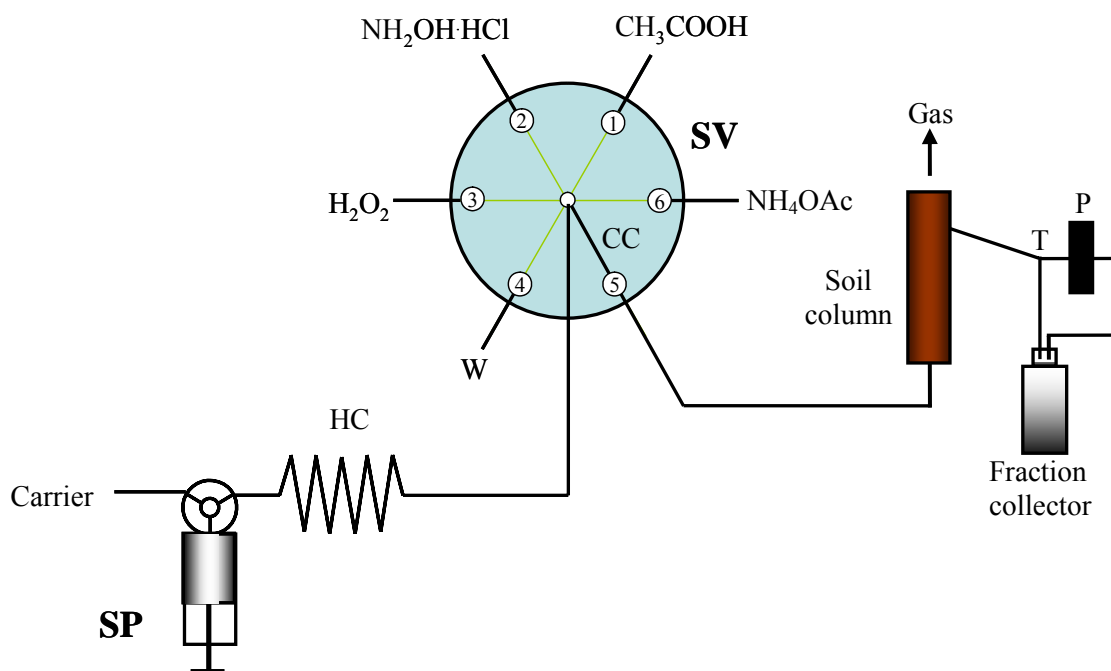

Fig. 5 Schematic diagram of the dynamic sequential extraction systems; SP, syringe pump; HC, holding coil; SV, selection valve; CC, central communication channel; W, waste; carrier, Milli-Q water; T, three ways valve; P, peristaltic pump.

Sample size

Contaminated sample : ca. 0.5-1 g

Normal sample : up to 5 g

Extraction flow rate : 2 mL/min

Uniform flow rates are obtained.

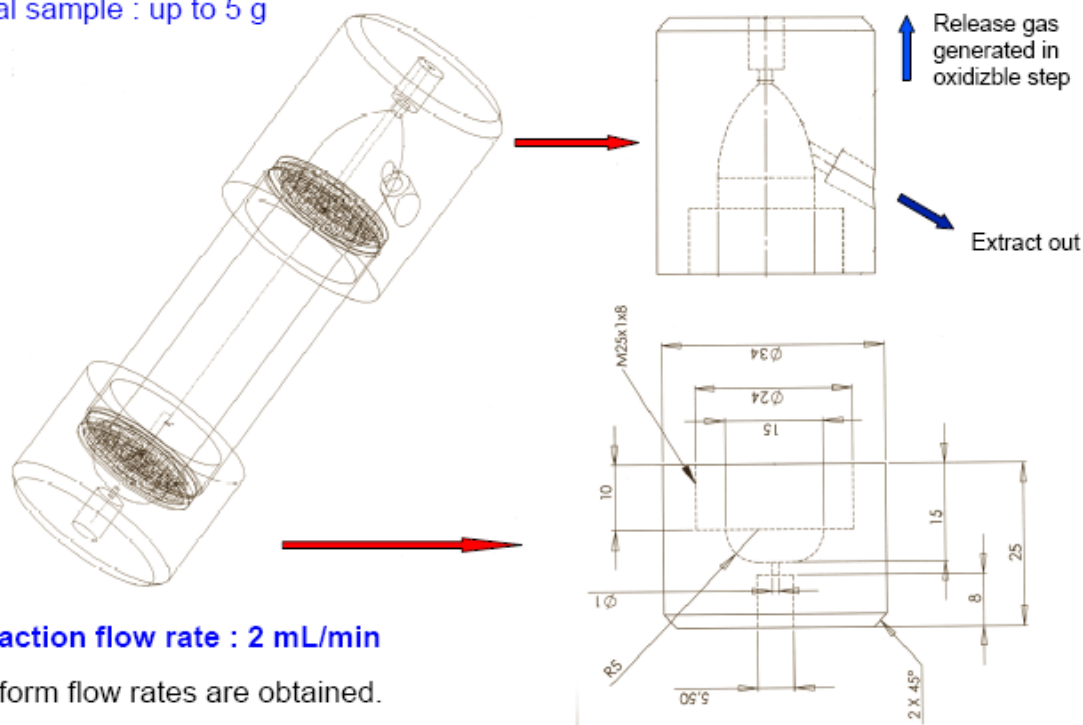

Fig. 6 Extraction column used for dynamic sequential extraction of radionuclides from soil and sediment samples

4.4. Investigation on Re-absorption of Pu during the fractionation of Pu in soil and sediment (Risø)

One of the most important problems with sequential extraction techniques is redistribution as a result of readsorption of dissolved metals onto the remaining solid phases during extraction. It has been recommended that the extraction time or contact time between the solid phase and the extracting reagent of the earlier steps of sequential extractions should be kept as short as possible to minimize the risk of readsorption to take place. Our previous work with dynamic extraction system incorporating the microextraction column to fractionate stable metals in soils and sediments has shown many advantages over the batch system, and one of the major ones is less readsorption. It was expected that the dynamic extraction system developed in this work would also reduce read-

sorption of radionuclides (Pu and Am) during fractionation in comparison with the conventional batch methods.

A double spiking technique was used to determine the extent of Pu and Am readsorption during sequential extraction. Known activities of ^{242}Pu and ^{243}Am tracers were spiked to the extractant in order to measure the degree of readsorption. Recoveries and the distributions of ^{242}Pu and ^{243}Am among different fractions are shown in Fig. 7 and Fig. 8, respectively. The results showed that recoveries of ^{242}Pu and ^{243}Am in different spiked steps in the batch and dynamic extraction systems are similar, except recovery of ^{243}Am at step I for dynamic system showed lower percentage (ca. 2%) in comparison with the batch system (ca. 9%). It was found that a very significant readsorption occurred in all steps. For example, recovery of spiked ^{242}Pu in the exchangeable step was 24% in average and less than 10% for ^{243}Am . In the acid soluble and the reducible fractions, recoveries of ^{242}Pu and ^{243}Am were less than 4% and 8%, respectively. A relatively low degree of readsorption in comparison with other steps was observed in the exchangeable fraction for Pu (ca. 76%, both methods) and for Am (ca. 90%, batch method). The main reason for these is probably because ammonium acetate entails a high complexing capacity due to the acetate ion which may prevent readsorption or precipitation of the released ions from the soil sample.

From the results (Fig. 7, 8), it was found that ^{242}Pu and ^{243}Am are redistributed among the remaining phases, especially to the oxidizable and residual fractions. The distribution of spiked Pu and Am showed similar patterns for both the dynamic and the batch procedures. Major amount of spiked ^{242}Pu (ca. 59%) and ^{243}Am (ca. 64%) were mainly redistributed to the oxidizable fraction (organic matter phase, step IV).

It should be borne in mind that in the oxidizable phase (step IV), the proposed dynamic extraction system was operated at room temperature by passing the extractant slowly through the soil column, which provided 4 h extraction time. The batch extraction was performed at room temperature (1 h) and at 85 °C (2 h). Therefore, the results from the dynamic system indicated that the percentages of leachability of radionuclides in this step were slightly lower than the batch system.

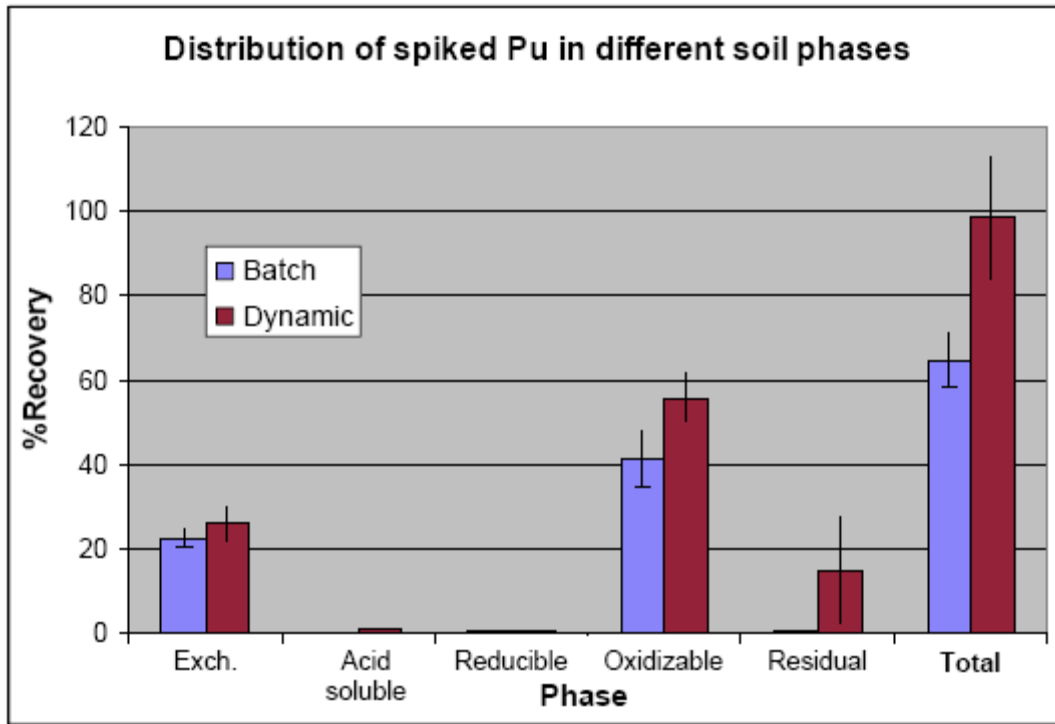

Fig. 7 Recoveries of spiked ^{242}Pu in each extraction step when comparing the dynamic and the batch extraction systems

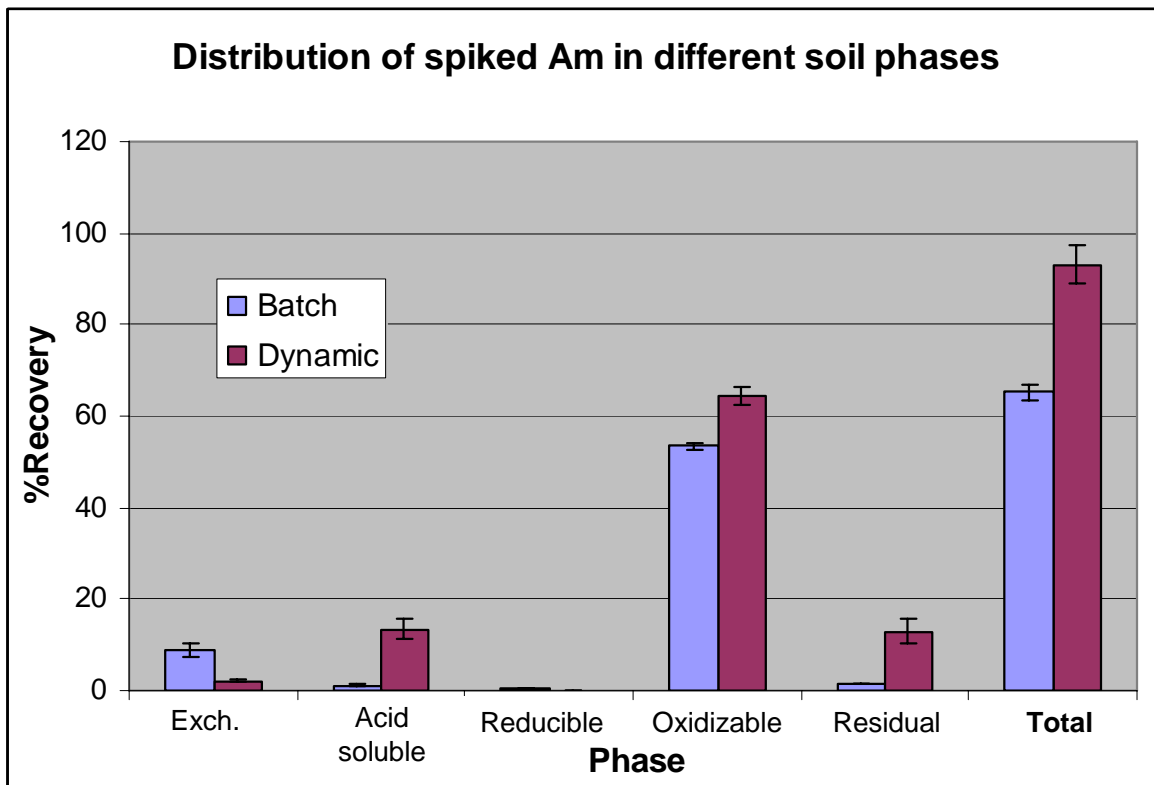

Fig. 8 Recoveries of spiked ^{243}Am in each extraction step when comparing the dynamic and the batch extraction systems

However, the extractable amounts of Pu and Am in this step were higher than our expectation. It might be because the newly readsorbed radionuclides were loosely bound to the organic matter. Recoveries of the extractable amount of radionuclides in the residual fraction (step V) using the dynamic extraction pro

This result indicates that the readsorption of Pu and Am occurs in a very short time scale. Even though extracts are rapidly removed from contact with the remaining solid phase in the dynamic system, the degree of readsorption is still high. However, based on the experimental results, it can be concluded that extractions performed by the dynamic approach are, still, preferable to those obtained with the batch procedures. The dynamic extraction system is a closed system providing no sample loss, less risk of personal errors, and eliminates external contamination. Therefore, it gives higher recoveries of the spiked radionuclides (ca. 89% as compared to ca. 67% recovery with the batch procedure). Besides, the continuous extraction approach mimics much better the real environmental conditions. The system is fully automated and computer-controlled. Uniform flow rates are obtained under the optimal operational conditions. Tedious procedures such as solid-liquid phase separation by centrifugation and manual filtration are completely eliminated. Washing between steps can be implemented simply by dispensing pure water to the column between extraction steps. The extraction time for the 4 steps comprises totally ca. 8 h as compared to ca. 50 h in the batch systems (even without considering the separation procedure by centrifuge and filtration). And it is possible to obtain more detailed knowledge of the leaching kinetics when highly contaminated samples are applied. Further studies are required to understand more about the readsorption events themselves, including factors affecting the degree of readsorption such as soil properties and how to solve or reduce this problem when performing dynamic sequential extraction procedures.

5. Progress in the investigation of speciation of the some radionuclides in specific Nordic environments

5.1 Speciation of ¹²⁹I in North Sea surface water (Risø/Uppsala University)

Surface seawater samples collected from the North Sea and English Channel were analyzed for total ^{129}I and ^{127}I as well as for iodide and iodate. The results (Fig. 9) show that relatively high ^{129}I concentrations ($2\text{-}3\times 10^{11}$ atoms/L) were observed in the northern part of the English Channel and in the south-eastern North Sea. The atomic ratio of $^{129}\text{I}/^{127}\text{I}$ decreases from the eastern ($1.0\text{-}1.9\times 10^{-6}$) to the western ($4\text{-}6\times 10^{-8}$) parts of the North Sea and from the north-eastern (1.5×10^{-6}) to south-western ($1\text{-}5\times 10^{-8}$) parts of the English Channel. The ratios of iodide to iodate are (0.1-0.5) and (0.5- 1.6) for the ^{127}I and ^{129}I , respectively, in open seawaters, whereas these ratios range at (0.6 -1.3) and (0.8-2.2) in coastal waters. The results suggest that: (1) Imprints of the La Hague facility dominates the ^{129}I distribution in the surface water of the North Sea; (2) Reduction of iodate to iodide is relatively fast during the transport to the European continental coast; (3) Oxidation of newly produced ^{129}I to $^{129}\text{IO}_3^-$ is insignificant during water exchange between the coastal area and open sea, and reduction of iodate; (4) Oxidation of iodide in the open sea seems to be a slow process.

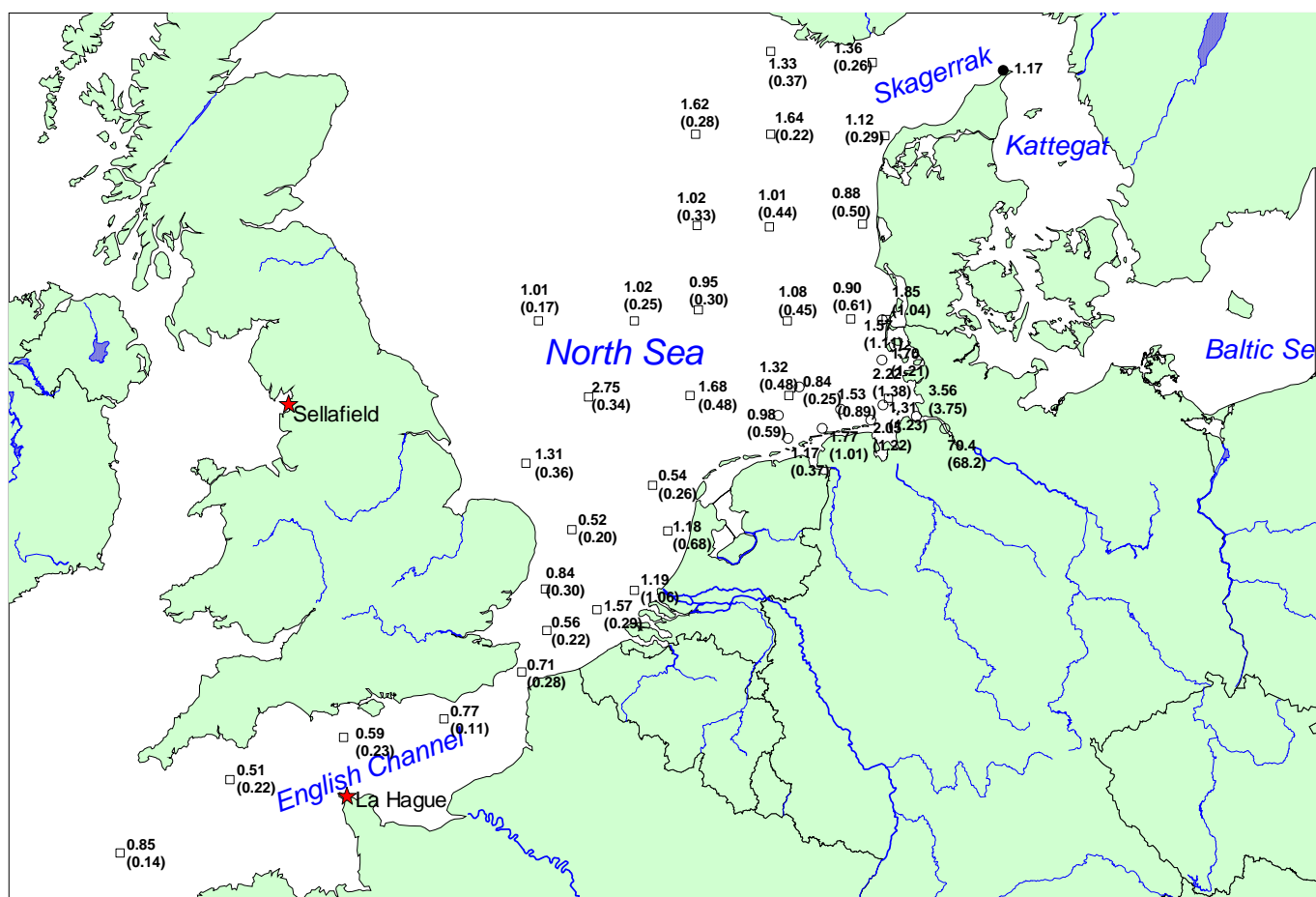

Fig. 9 Distribution of iodide/iodate ratios for ^{129}I (upper number) and ^{127}I (in parentheses) in surface seawater from the English Channel and North Sea

5.2. Partition of ^{137}Cs and ^{129}I in the Nordic lake sediment, pore-water and lake water (Uppsala University)

To quantify partitioning of the radioactive isotopes between solid and liquid phases and estimation of the isotope migration within soil and lake sediment profiles. Sediment cores were collected from a small lake in central Sweden (Loppesjön); a region characterised by relatively high Chernobyl fallout. With the view that a period of about 20 years has passed since the Chernobyl fallout, we aimed at investigating whether the fallout horizon has been stationary or if it has migrated within the sediment column. Furthermore, we explored interaction between the pore water and enclosing sediment and possible dispersion within the sediment profile and to the sediment-water inter-phase. The sampling was done during winter of 2006 from a frozen lake surface and through direct core slicing. Sediment and pore water were separated and used to evaluate these hypotheses. Although we have measured the distribution of ^{137}Cs , our main focus was on the distribution of ^{129}I . The ^{129}I occurs in minute quantities (10^{7-9} atoms/g sediment or water) in nature and thus is measured with the accelerator mass spectrometry technique (AMS). Some improvement of the analytical techniques for the determination of ^{129}I by AMS was carried out, which includes minimizing the amount of sample to a degree that a few mm-wide sediment layers as well as a few ml of the pore water in a core can be sampled and measured. Furthermore, because of the rather heavy contamination of the Nordic atmosphere with anthropogenic releases of ^{129}I , ultra clean laboratory conditions, preparation procedure and chemicals have been established. In addition, to increase detection limit of the AMS system a time of flight detector is used for near background concentration values.

Our preliminary results on the distribution of ^{137}Cs and ^{129}I in the lake sediment, pore-water and lake water show interesting partitioning behaviour. The data suggest a rather constant and conservative behaviour of the ^{137}Cs -rich sediment layer (Chernobyl) without observable migration compared to previous measurement, during 1996, at the same part of the lake. This ^{137}Cs coincidence was used to estimate possible migration in the ^{129}I isotope through the sediment profile. The data show indication of an upward migration of the ^{129}I -Chernobyl related layer. Data on the ^{129}I distribution in the pore water also support an upward migration of the isotope. However, the partition between pore-water and sediment was relatively small (a few %) suggesting that most of the ^{129}I was kept in immobile speciation forms in sediment particles. The amount of ^{129}I in the lake water along the sediment-water inter-phase is about several times higher than what is found in the lake water. This observation indicates that some fraction of ^{129}I are released from the sediment to the water through possible decomposition of organic matters (an iodine-rich source).

The next stage of our project is to exactly specify the type of iodine speciation in all sediment-water compartments as well as in the biota (animals and vegetation). This approach is vital in order to in-

investigate the rate of ^{129}I mobility and the speciation forms that are most appealing to nutrient chain and the bio-availability of the isotope in the ecosystem.

5.3. Sequential extraction of Pu in soil, sediment and concrete samples (Risø)

The developed dynamic extraction method has been used to investigate the fractionation of Pu in soil collected from Thule, Greenland and heavy contamination area near Chernobyl power plant, sediment samples collected from Thule, Greenland, Palomares, Spain and Irish Sea, and concrete samples from the concrete shielding in Danish DK-2 research reactor which was decommissioned.

The result (Table 1) shows that most of Pu was associated to organic and oxides fractions and small fraction of Pu exists as mobile or bioavailable form (exchangeable and carbonate) in soil and sediment. However, in concrete sample, a large fraction of Pu exists as mobile for (carbonate), very less associated to organic fraction. To our best knowledge, this is the first investigation of the Pu fractionation in concrete, the results are very important in the view of waste disposal.

Table 1 Sequential fractionation of $^{239,240}\text{Pu}$ (Bq/kg) in soil, sediment, and concrete samples using dynamic sequential extraction system.

Sample	Rep.	Step 1 ^a (NH_4OAc)	Step 2 ^a (CH_3COOH)	Step 3 ^a ($\text{NH}_2\text{OH}\cdot\text{HCl}$)	Step 4 ^a (H_2O_2)	Step 5 ^a (Aqua regia)	Total ^a (1+2+3+4+5)	Total ^b (Aqua regia)
Thule Soil	1	0.37	0.26	20.5	0.76	27.9	49.8	56.5 ± 1.5
	2	0.30	0.34	17.6	0.60	35.1	53.9	
Chernobyl Soil	1	0.08	0.07	0.04	0.39	0.46	1.04	0.86 ± 0.18
	2	0.04	0.06	0.04	0.45	0.86	1.46	
Thule Sediment	1	<DL	<DL	<DL	<DL	3.71	3.71	3.90 8.60
	2	<DL	<DL	1.13	3.45	23.5	28.1	
Palomares Sediment	1	11.6	14.8	52.8	6.9	3481	3568	4006 ± 46
	2	10.1	11.8	36.5	20.4	2458	2537	
Irish Sea Sediment	1	1.49	3.02	44.6	213	46.8	309	344 ± 7.5
	2	1.90	2.26	52.0	0.90	282.4	339	
Concrete no.5	1	0.10	0.44	0.40	<DL	<DL	0.94	NA
Concrete no.6	1	<DL	0.07	0.17	<DL	<DL	0.24	0.23 ± 0.08
	2	<DL	0.05	0.11	0.16	<DL	0.32	

5.4. Pu sorption to Mn and Fe oxides in the geological material (Institute of Physics, Lithuania)

Speciation of radionuclides was studied with the aim of better understanding their sorption mechanism to the clay minerals selected as engineered barrier for the cement (concrete) based near surface low and intermediate level waste repository.

Recently in different publications the association of actinides with oxides and application of different methods for speciation determination have been discussed. Data on association of plutonium with geological material was found to be rather contradictory. McDonald et al. found that plutonium is predominantly associated with Fe, Mn oxyhydroxides (43.9 %) and organic complexes (43.5%) in the Irish Sea sediments, whereas McCubbin et al. reported 37 % of Pu as upper limits for the fraction associated with magnetic + nonmagnetic Fe minerals in samples collected at close area of the Cumbarian coast [1,2]. Data was obtained using different methods: sequential extraction and magnetic extraction technique. Using selective extraction procedures was shown that Pu was associated predominantly with Mn oxides. The dominant association with the Mn oxides occurred despite the fact that the Fe oxides were present at concentrations higher by factor from 2 to 30 in comparison with the Mn oxides [3].

X-ray absorption spectroscopy, in combination with microautoradiography, electron microprobe, and petrographic microscopy techniques were used to detect the spatial distribution of sorbed Pu on the zeolitic Topopah Spring Tuff sampled at Yucca Mountain [4,5]. Large concentrations of sorbed Pu were associated with smectite and Mn oxide fracture minerals. Sorption of Pu to Fe-rich regions was not observed. In a similar experiment in which Tuff was used, Pu was concentrated in the zones of altered orthopyroxenes. These zones contained Fe-rich amorphous materials [6].

In order to obtain information about Pu sorption to Mn and Fe oxides in the geological material, we used the sequential extraction methods with leaching controlled by means of AAS and Mössbauer spectrometry. The experiments were conducted in a wide range of electrolyte solutions. The concentrations of studied radionuclides in the solutions were as follows: $C(\text{Cs}) = 2.30 \cdot 10^{-10}$ mol/L, $C(\text{Cs}) = 6.80 \cdot 10^{-5}$ mol/L, $C(\sum\text{Pu}) = 1.10 \cdot 10^{-9}$ mol/L and $C(\text{Am}) = 3.20 \cdot 10^{-11}$ mol/L. Pu(IV) was used in sorption experiments [7, 8]. The oxidation state purity of Pu(IV) stock solution was analyzed by solvent extraction at pH 0.5 using 0.5 M TTA as extractant. In addition, oxidation state analyses were performed in the groundwater and the cement-water solutions using TTA and HDEHP as extractants. The tests were performed under atmosphere conditions at 25°C. Measurements of Cs, Pu and Am were carried out using γ - and α - spectrometry.

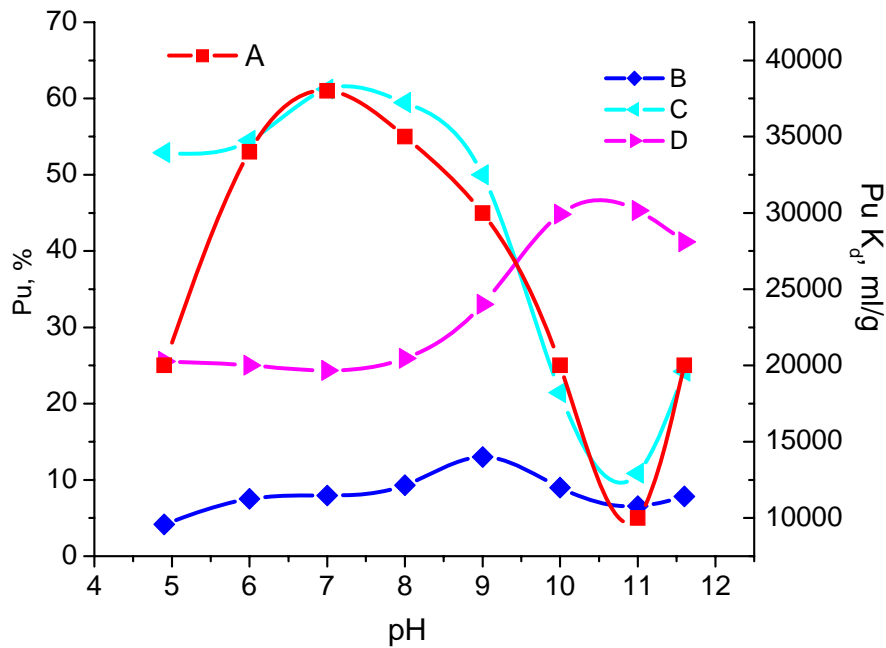

Fig.10 Variations of plutonium K_d values (A) and percentage of sorbed Pu to various geochemical phases (B – CaCO_3 , FeCO_3 ; C – $\alpha\text{-FeOOH}$, FeCO_3 ; D – $\alpha\text{-Fe}_2\text{O}_3$) depending on pH of cement-water solutions.

Comparatively similar amount of Mn found in all fractions of sequential extraction was interpreted as a trace amount of Mn oxides distributed almost equally between other minerals [9]. Mn-oxides were not identified by the X-ray diffraction analysis due to the small amount present were not taken into account in the explanation of the Pu sorption mechanism. Variations of Pu speciation in clay under different sorption conditions were explained by Pu redox speciation found in groundwater and cement-water solutions and different iron oxide (siderite - FeCO_3 ; goethite - $\alpha\text{-FeOOH}$ and hematite - $\alpha\text{-Fe}_2\text{O}_3$) coatings identified by Mössbauer spectrometry in the initial samples and after different steps of sequential extraction (Fig.10).

The possible sorption mechanism deals with the adsorption of soluble Pu (IV) and PuO_2^+ (via reduction of Pu(V) to Pu(IV)) onto goethite in the range of pH from 5 to 7.8 and formation of hydrolytic species on the surface of the iron oxide: $\equiv\text{SO-Pu}(\text{OH})_2^+$, $\equiv\text{SO-Pu}(\text{OH})_2^{2+}$, $\equiv\text{SO-Pu}(\text{OH})_3^+$, and $\equiv\text{SO-Pu}(\text{OH})_3^0$ where $\equiv\text{SO}$ denotes surface sites on the iron oxides. Plutonium aqueous speciation and sorption under high pH are poorly understood. However, surface complexation of Pu(IV) to calcite surface ($>\text{Ca}^+ + \text{Pu}^{4+} + 2\text{HCO}_3^- + 2\text{H}_2\text{O} = >\text{CaCO}_3\text{Pu}(\text{OH})_2\text{CO}_3^- + 4\text{H}^+$) and in similar way to siderite can be responsible for retention Pu by clay minerals. Probably the surface complexation (with further incorporation into minerals) of Pu(IV) on iron oxides via formation of the surface carboxylic groups ($\equiv\text{Fe-OH} + \text{H}^+ + \text{CO}_3^{2-} \leftrightarrow \equiv\text{Fe-OCOO}^- + \text{H}_2\text{O}$) suggested by Fujita and Tsukamoto probably could explain the sorption behavior of Pu(IV) at high pH [10].

Changes in K_d values of Cs, Pu and Am depending on pH, ionic strength and chemical composition of solutions as well as mineralogical composition of clay minerals from 450 to 9700, from 15000 to 21000 and from 15000 to 80000 ml/g, respectively were observed. Results of kinetic tracer experiments and sequential extraction studies reveal differences in sorption mechanisms depending on the Cs concentration [2]. Rather different behaviour of Am was observed, up to 40% of Am was found in exchangeable and carbonate bound fractions [11].

References

1. P. McDonald, G.T. Cook, M.S. Baxter, J.C. Thompson, J. Environ. Radioactivity, 21 (1990) 77.
2. D. McCubbin, K. S. Leonard, A. K. Young, B. A. Maher, S. Bennett, J. Environ. Radioactivity, 77 (2004) 111.
3. J.L. Means, D.A. Crerar, M.P. Borcsik and J.O. Duguid, Geochimica Acta, 42 (1978) 763.
4. M.C. Duff, D.B. Hunter, I.R. Triay, P.M. Bertsch, D.T. Reed, S.R. Sutton, G. Shea-McCarthy, J. Kitten, P. Eng, S.J. Chipera, and D.T. Vaniman, Environ. Sci. Tech., 33 (1999) 2163.
5. M.C. Duff, M. Newville, D.B. Hunter, P.M. Bertsch, S.R. Sutton, I.R. Triay, D.T. Vaniman, P. Eng and M.L. Rivers, J. Synchrotron Radiation, 6 (1999) 350.
6. D. Vaniman, A. Furlano, S. Chipera, J. Thompson, and I. Triay, Proc. Symp. Mat. Res. Soc., 412 (1996) 639.
7. Lujanienė, G.; Motiejūnas, S.; Šapolaitė, J.; Kamarauskas, Ž. Lithuanian journal of physics. Vol. 45, No.4 (2005) 273.
8. Lujanienė, G.; Mažeika, K.; Šapolaitė, J.; Amulevičius, A. S.; Motiejūnas, S. Lithuanian journal of physics. Vol. 46, No. 3 (2006) 375.
9. Lujanienė, G., Šapolaitė, J., Amulevičius, A., S., Mažeika, K., Motiejūnas, S. Czechoslovak journal of physics. Vol.56, suppl.D (2006) D103.
10. Fujita T. and Tsukamoto M. Mat. Res. Soc. Symp. Proc., 465 (1997) 781.
11. Lujanienė G., Motiejūnas S., Šapolaitė J. Journal of Radioanalytical and Nuclear Chemistry, 274, 4 (2007) 345.

5.5 Investigation of the adsorbed species of lanthanides and actinides on clays surfaces (University of Helsinki)

Jukka Lehto has been writing a university text book on chemistry and analysis on radionuclides a large part of which will discuss on speciation of radionuclides. In 2007 in the Laboratory of Radiochemistry started a new project in which speciation has a special focus. In this project, forms of trivalent lanthanides and actinides in solutions and as adsorbed species on clays surfaces are studied by IR, NMR and Laser Induced Fluorescence Spectrometry.

6. Structure of review articles

Two review articles are planned by the project members, one focus on the speciation of plutonium in the environment and another focus on the speciation of iodine (^{129}I) in the environment. UMB will make a first draft of manuscript of plutonium, and Risø/Uppsala University will make a draft of the manuscript of iodine. But all partners of the project will contribute some part to both articles. It is planned to finish and submit the two articles in the end of March 2008 to an international journal for publication (*Analytica Chimica Acta*). The structures of the articles were planned and are shown below.

6.1 Speciation of Plutonium in Environmental Samples (Content)

1. Introduction (LS/BS)
 - 1.1. Definitions
 - 1.2. Relevance
 - 1.3. Input to impact and risk assessment models
2. Relevance for ecosystem transfer (BS/LS) Environmental aspects of Pu
 - 2.1. Past, existing and potential sources of Pu contamination
 - 2.2. Source Term Characteristics Including Physicochemical Forms
 - 2.2.1. Release conditions and transport pathways Atmospheric etc
 - 2.3. Environmental Pu chemistry in waters
 - 2.4. Mobility in soils and sediments
 - 2.5. Biological uptake and effects
3. Separation techniques (LS/BS/OCL)
 - 3.1 Aquatic phases
 - 3.1.1. Size fractionation
 - 3.1.1.1. Filtration
 - 3.1.2. Ultrafiltration
 - 3.1.2.1. Hollow fibre
 - 3.1.2.2. Tangential Flow Filtration
 - 3.1.3. Redox Techniques/Oxidation state distribution
 - 3.2. Solid phases
 - 3.2.1. Sequential extraction
4. Measurement techniques for determination of Pu
 - 4.1 Radiometric
 - 4.1.1 α -spectrometry
 - 4.1.2 Liquid scintillation spectrometry

4.2 Mass spectrometry

4.2.1 ICP-MS

4.2.2 AMS

5. Characterization of Pu in particles

5.1 Autoradiography Identification/isolation

5.1.1 Digital autoradiography: Palomares, Thule, Semipalatinsk

5.1.2 Fission track

5.2 Microanalytical techniques

5.2.1 Electron microscopy

5.2.2 SEM and ESEM with X-ray microanalysis

5.2.3 TEM with X-ray microanalysis

5.2.3.1 EELS

5.2.3.2 Electron diffraction

5.3 Synchrotron radiation based micro beam techniques

5.3.1 μ -XRF:

5.3.2 μ -XAS

5.3.3 μ -XRD

5.3.4 μ -PIXE TAB left

5.4 Laser-induced Spectroscopic Methods

5.5 SIMS

5.6 μ -RAMAN

6. Discussion

6.1 Perspective

6.2 Future developments

7. Conclusions (LS)

6.2 Speciation of Iodine (^{129}I) in the Environment (Content)

1 Introduction

1.1 Background

1.2 Why speciation of radionuclides, specifically for iodine and ^{129}I ,

1.3 equilibrium of ^{129}I in environment

1.4 Purpose of this article

2. Sources of ^{129}I in the environment

- 2.1 Natural occurring (cosmic generated, weapon testing, operation of nuclear reactor, nuclear accidents reprocessing plants)
- 2.2 Releasing history (weapons test, Chernobyl, reprocessing)
- 2.3 Inventory in the environment
- 2.4 Concentration in the environment
- 2.5 Pathway
- 2.6 Speciation in the source materials
- 3. Analytical methods for the determination of ^{129}I in the environmental samples
 - 3.1 Accelerator mass spectrometry
 - 3.2 Radiochemical neutron activation analysis
 - 3.3 Liquid scintillation counting
 - 3.4 Gamma and X-ray spectrometry
- 4. Speciation analysis of ^{129}I in environment and its application
 - 4.1 Seawater (Iodide, iodate, organic iodine)
 - 4.2 Fresh water (precipitation, lake and river water)
 - 4.3 Air (particle associated, inorganic gas (HI , HIO , I_2), organic gas (CH_3I , CH_2I_2 , etc.))
 - 4.4 Groundwater/brine water
 - 4.5 Soil and sediment (Fractionation, exchangeable, carbonate, organic, oxides, residue)
 - 4.6 Plants (seaweeds, tree rings, etc.)
- 5. Availability and radiation toxicity of ^{129}I
 - 5.1 Uptake and absorption of different forms of iodine by humans and animals
 - 5.2 Chemical toxicity of different forms of iodine
 - 5.3 Radiation dose and toxicity of ^{129}I
- 6. Conclusion
 - 6.1 General information available
 - 6.2 Potential release
 - 6.3 What is missing (anoxic condition)
 - 6.4 Prospect for the future work

Publications:

1. Hou, X.L., Aldahan, A., Nielsen, S.P., Possnert, G., Niels, H., Speciation of ^{129}I and ^{127}I in seawater and implications for sources and transport pathways in the North Sea, *Environ. Sci. Tech.*, 41(2007)4993-5999.
2. Persson, S., Aldahan, A., Possnert, G., Alfimov, V., Hou, X.L., ^{129}I Variability in precipitation over Europe, *Nuclear Instruments and Methods in Physics Research Section B*, 259(2007)508-512.

3. Aldahan, A.; Englund, E.; Possnert, G.; Cato, I.; Hou, X.L., Iodine-129 enrichment in sediment of the Baltic Sea. *Appl. Geochem.* 22(2007)637-647
4. Hou X.L. Roos, P., Critical comparison of radiometric and mass spectrometric methods for the determination of radionuclides in biological, environmental and waste samples. *Anal. Chim. Acta.*, 2007, in press.
5. Pertersen R., Hou X.L., Hansen E.H., Evaluation of the readsorption of plutonium and americium in dynamic fractionations of environmental solid sample, *J. Environ. Radioact.*, 2007, accepted.
6. Hou, X.L. Iodine Speciation in Foodstuff, Tissues and Environmental samples, -- Iodine species and analytical method, *Comprehensive Handbook of Iodine*, Academic Press, 2007. in press

Presentations in NKS speciation seminar, UMB, Ås, Norway, April 19th and 20th, 2007

- Xiaolin Hou, Risø, Denmark, Chemical speciation of ¹²⁹I in North Sea water and its application for the study of marine geochemical cycle of stable iodine.
- Ole Christian Lind, UMB, Norway, Size fractionation and accelerator mass spectrometry analysis of Pu in the Ob and Yenisey rivers.
- Jussi Jernström, Risø/University of Helsinki, Metal concentrations in the sediments of Lake Umbozero in Kola, Russia
- Roongrat Petersen, Risø, Denmark, Dynamic Chemical Fractionation of Metals and Radionuclides in Soils and Sediments.
- Lindis Skipperud, UMB, Norway, Association of Plutonium with soil and sediments contaminated from Mayak and Krasnoyarsk nuclear installations
- Galina Lujanienė, Institute of Physics, Lithuania, Cs, Pu and Am speciation and sorption behaviour under cement-based repository conditions.
- Brit Salbu, UMB, Norway, Fractionation techniques useful for speciation studies.

Title	Speciation Analysis of Radionuclides in the Environment. NKS-B Speciation project report 2007
Author(s)	Xiaolin Hou (1), Ala Aldahan (2), Göran Possnert (3), Galina Lujaniene (4), Juka Lehto (5) and Brit Salbu (6)
Affiliation(s)	(1) Risø National Laboratory for Sustainable Energy, Technical university of Denmark, DK-4000 Roskilde, Denmark; (2) Uppsala University, Department of Earth Science, Villavägen 16, SE-752 36 Uppsala, Sweden; (3) Uppsala University, Tandem Laboratory, Uppsala University, SE-751 21 Uppsala, Sweden; (4) Institute of Physics, Savanoriu 231, LT-0230 Vilnius, Lithuania; (5) University of Helsinki, Department of Chemistry, P.O. Box 55, FI-00014 Helsinki, Finland; (6) Norwegian University of Life Sciences (UMB), P.O.Box 5003, NO-1432 Ås, Norway
ISBN	978-87-7893-242-6
Date	July 2008
Project	NKS-B / SPECIATION 2007
No. of pages	29
No. of tables	1
No. of illustrations	10
No. of references	33
Abstract	<p>This report describes the work carried out under the NUK-B project SPECIATION 2007. In 2007, the project partners had two meetings in April and November, organized a NUK seminar on speciation and hot particles. SPECIATION 2007 mainly focused on two issues on speciation (1) further development of speciation methods for radionuclides, and (2) investigation of speciation of radionuclides in environment. The report summarized the work done in partners labs, which includes: (1) Further development on the speciation of ¹²⁹I and ¹²⁷I in water samples; (2) Speciation method for ¹²⁹I and ¹²⁷I in air; (3) Dynamic system for fractionation of Pu and Am in soil and sediment; (4) Investigation on Re-absorption of Pu during the fractionation of Pu in soil and sediment; (5) Speciation of ¹²⁹I in North Sea surface water; (6) Partition of ¹³⁷Cs and ¹²⁹I in the Nordic lake sediment, pore-water and lake water; (7) Sequential extraction of Pu in soil, sediment and concrete samples, (8) Pu sorption to Mn and Fe oxides in the geological materials, (10) Investigation of the adsorbed species of lanthanides and actinides on clays surfaces. In addition, two review articles on the speciation of plutonium and iodine in environment have been planned to be submitted to an international journal for publication.</p>
Key words	Speciation, radionuclides, radioecology, radioanalytical chemistry, ¹²⁹ I, plutonium, fractionation, dynamic system